

ROUTINE

MWO effective date is 1 February 1996, and completion date is 31 January 2000.

MWO 9-2320-272-20-5

**FRONT LIFTING PIN AND SHACKLE KIT
MODIFICATION WORK ORDER**

**MODIFICATION OF 5-TON
M939 AND M939A1 SERIES TRUCKS**

NOMENCLATURE	NSN	EIC	NOMENCLATURE	NSN	EIC
Truck, Cargo, Dropside	2320-01-050-2084	BRY	Truck, Tractor	2320-01-047-8753	BTE
Truck, Cargo, Dropside	2320-01-206-4087	BSS	Truck, Tractor	2320-01-206-4077	BS2
Truck, Cargo, Dropside	2320-01-047-8769	BRT	Truck, Tractor	2320-01-047-8752	BTD
Truck, Cargo, Dropside	2320-01-206-4088	BST	Truck, Tractor	2320-01-205-2684	BS3
Truck, Cargo, XLWB	2320-01-047-8771	BRV	Truck, Van,		
Truck, Cargo, XLWB	2320-01-206-4089	BSW	Expansible	2320-01-047-8750	BTB
Truck, Cargo, XLWB	2320-01-047-8770	BRU	Truck, Van,		
Truck, Cargo, XLWB	2320-01-206-4090	BSX	Expansible	2320-01-205-2682	BS4
Truck, Dump	2320-01-047-8756	BTH	Truck, Medium,		
Truck, Dump	2320-01-206-4079	BSY	Wrecker	2320-01-047-8754	BTF
Truck, Dump	2320-01-047-8755	BTG	Truck, Medium,		
Truck, Dump	2320-01-206-4080		Wrecker	2320-01-206-4078	BS6
BSZChassis	2320-01-205-2666		Chassis	2320-01-047-8745	
Chassis	2320-01-230-0287		Chassis	2320-01-230-0288	
Chassis	2320-01-205-2667		Chassis	2320-01-050-4894	

Headquarters, Department of the Army, Washington, D.C.

1 February 1996

REPORTING OF ERRORS AND RECOMMENDING IMPROVEMENTS

You can help improve this MWO. If you find any mistakes or if you know of a way to improve these procedures, please let us know Write a letter or complete and mail a DA Form 2028, Recommended Changes to Publications and Blank Forms, to U S. Army Tank-automotive and Armaments Command, ATTN AMSTA-IM-MMAA, Warren, MI 48397-5000 A reply will be provided to you

DISTRIBUTION STATEMENT A. Approved for public release, distribution is unlimited.

1. PURPOSE.

The purpose of this modification is to provide improved front lifting shackles

2. PRIORITY.

This modification is classified as ROUTINE

3. END ITEM TO BE MODIFIED.

a. 5-ton, 6x6, M939 and M939A1 series vehicles

NOMENCLATURE	NSN	EIC	PART NO.	CAGE C	MODEL NO.
Truck, Cargo, Dropside	2320-01-050-2084	BRY	8736986-2	19207	M923
Truck, Cargo, Dropside	2320-01-206-4087	BSS	8750151	19207	M923A1
Truck, Cargo, Dropside	2320-01-047-8769	BRT	8736986-1	19207	M925
Truck, Cargo, Dropside	2320-01-206-4088	BST	8750152	19207	M925A1
Truck, Cargo, XLWB	2320-01-047-8771	BRV	8736987-1	19207	M927
Truck, Cargo, XLWB	2320-01-206-4089	BSW	8750155	19207	M927A1
Truck, Cargo, XLWB	2320-01-047-8770	BRU	8736987-1	19207	M928
Truck, Cargo, XLWB	2320-01-206-4090	BSX	8750156	19207	M928A1
Truck, Dump	2320-01-047-8756	BTH	8736989-2	19207	M929
Truck, Dump	2320-01-206-4079	BSY	8750157	19207	M929A1
Truck, Dump	2320-01-047-8755	BTG	8736989-1	19207	M930
Truck, Dump	2320-01-206-4080	BSZ	8750158	19207	M930A1
Truck, Tractor	2320-01-047-8753	BTE	8736990-2	19207	M931
Truck, Tractor	2320-01-206-4077	BS2	8750159	19207	M931A1
Truck, Tractor	2320-01-047-8752	BTD	8736990-1	19207	M932
Truck, Tractor	2320-01-205-2684	BS3	8750160	19207	M932A1
Truck, Van, Expansive	2320-01-047-8750	BTB	8736992	19207	M934
Truck, Van, Expansive	2320-01-205-2682	BS4	8750161	19207	M934A1
Truck, Medium, Wrecker	2320-01-047-8754	BTF	8736988	19207	M936
Truck, Medium, Wrecker	2320-01-206-4078	BS6	8750163	19207	M936A1
Chassis	2320-01-047-8745		8736983	19207	M942
Chassis	2320-01-205-2666		8750148	19207	M942A1
Chassis	2320-01-230-0287		8750190	19207	M942A2
Chassis	2320-01-205-2667		8750149	19207	M944A1
Chassis	2320-01-230-0288		8750191	19207	M944A2
Chassis	2320-01-050-4894		8736984	19207	M945

b. The vehicles' National Stock Numbers (NSNs) will not change as a result of this MWO

4. MODULE.

Not applicable

5. PARTS TO BE MODIFIED.

Not applicable.

6. APPLICATION.

- a. Time compliance schedule MWO effective date is 1 February 1996 and completion date is 31 January 2000
- b. The lowest level of maintenance authorized to apply the MWO is unit maintenance
- c. Work force and man-hour requirements for application of the MWO to a single unit, end item, or system are as follows

REQUIREMENTS	
WORK FORCE/SKILLS	MAN-HOURS
1 Wheeled Vehicle Mechanic (MOS 63B) or equivalent	1 0
Total man-hours required for a single application of this MWO is 1 hour	

- d. There is no other MWO that must be applied prior to application of this MWO
- e. There is no additional information necessary to apply to this MWO

7. TECHNICAL PUBLICATIONS AFFECTED/CHANGED AS A RESULT OF THE MWO.

Technical Publication	Date
TM 9-2320-272-10	25 July 1984, w/chg 5, 7 Jun, 1993
TM 9-2320-272-20	25 October 1985, w/chg 3, 25 Mar, 1991
TM 9-2320-272-20P	02 September 1988
TM 9-2320-272-34P-1	12 May 1988

8. MWO KITS, PARTS, AND THEIR DISPOSITION.

- a. The following kit is required to accomplish this modification The security classification of the kit is unclassified Shipping data (estimated) are weight 5 lbs; measurements 7 1 x 5 3 x 4 0 inches, volume 0 087 cu ft.

NSN	NOMENCLATURE	CAGEC	PART NO.
4030-01-372-9833	Front Lifting Pin and Shackle Kit	19207	12432386

- b. The Front Lifting Pin and Shackle Kit component parts are listed below. This listing is used to inventory the kit for completeness

NSN	NOMENCLATURE	CAGEC	PART NO.	QTY
4030-01-222-6037	Shackle, Lifting	19207	12301040	2
5315-01-333-6603	Pin and Chain Assembly	19207	12375352	2

- c. No bulk or expendable materials are required to apply the Front Lifting Pin and Shackle Kit.
- d. Part Disposition All parts not used during installation of the kit will be returned to stock for disposition in accordance with AR 725-50

e. The items listed below are not included in the Front Lifting Pin and Shackle Kit and must be requisitioned from stock

NSN	NOMENCLATURE	CAGEC	PART NO.	QTY
9905-00-858-5682	Plate, Instruction, MWO	19207	10930014	1
5305-00-253-5614	Drivescrew	96906	MS21318-20	1

9. SPECIAL TOOLS; TOOL KITS; JIGS; TEST, MEASUREMENT, AND DIAGNOSTIC EQUIPMENT (TMDE); AND FIXTURES REQUIRED.

No special tools, tool kits, jigs, TMDE, or fixtures are required to install the Front Lifting Pin and Shackle Kit

10. MODIFICATION PROCEDURES.

a. Vehicle Preparation

- (1) Set parking brake (TM 9-2320-272-10)
- (2) Remove retaining clip from pin as shown in figure 1
- (3) Remove pin and lifting shackle from shackle bracket Return lifting shackle and pin and chain assembly for disposition as shown is figure 1

b. Kit Installation

- (1) Install 12301040 lifting shackle on shackle bracket with 12375352 pin and chain assembly as shown in figure 2
- (2) Install retaining clip through hole in pin as shown in figure 2

11. CALIBRATION REQUIREMENTS.

Not applicable to this MWO

12. WEIGHT AND BALANCE DATA.

Weight and balance are not significantly affected by this MWO

13. QUALITY ASSURANCE REQUIREMENTS.

a. General. The following information is supplied to ensure the proper application of this modification and provide clarification in regard to the adequacy of the installer’s inspection methods and procedures applicable to quality assurance The procedures include, but are not limited to, installer responsibilities, government verification, and in-process and workmanship inspections. Inspections shall be in accordance with TM 750-245-4

b. Installer Responsibilities. The installer is responsible for compliance with quality assurance requirements specified herein. These requirements and the Installer’s plan of inspection, or quality program, constitute the minimum examinations and tests necessary to assure compliance with established requirements. Requirements contained in this MWO shall be included in the installer’s inspection plan or quality program These requirements shall not be construed as eliminating the installer’s responsibility from complete compliance with all the provisions of the contract. Specific installer responsibilities for this modification work order are as follows. The installer is responsible for following instructions contained in this MWO, for installation of the Front Lifting Pin and Shackle Kit, and for follow-on tasks IAW MWO 9-2320-272-20-5. Installer is responsible for notifying the Government representative if kit was received incomplete or received in open or damaged packaging material The installer is responsible for quality workmanship.

c. In-Process Inspection. During normal assembly operations, paragraph 10, Modification Procedures, will be used to check the installer's work. If front lifting shackles fail to operate properly after kit installation, servicing will be conducted in accordance with TM 9-2320-272-20 All defects will be corrected by the installer before the vehicle is placed in service All vehicles modified during a production shift will be checked to ensure product quality

d. Workmanship Inspection. Inspect components removed, Installed, or replaced during the modification for security of mounting Inspect painted areas of the bumper for missing, chipped, or cracked paint and correct if necessary.

14. RECORDING AND REPORTING OF THE MODIFICATION.

a. Records and report forms Refer to DA PAM 738-750, DA PAM 738-751, and TB 9-1100-803-15

b. Marking Equipment

(1) After Front Lifting Pin and Shackle Kit is installed, mark MWO number "MWO 9-2320-272-20-5" in the MWO applied block and date in date block on MWO Instruction Plate NSN 9905-00-858-5682.

(2) Install MWO data plate by drilling a hole (#37 drill) in cab body reinforcement panel and secure with drivescrew NSN 5305-00-253-5614 as shown in figure 3.

(3) After drivescrew is installed, flatten or remove protruding excess drivescrew material from inside of cab body reinforcement panel.

c. Identification Data Not applicable

15. MATERIAL CHANGE (MC) NUMBER.

This MWO is authorized by MC number 1-88-06-4205

16. MODIFICATION IDENTIFICATION.

When the Front Lifting Pin and Shackle Kit is installed, it will be identified by the MWO Instruction Plate mounted on the cab reinforcement panel as shown in figure 3

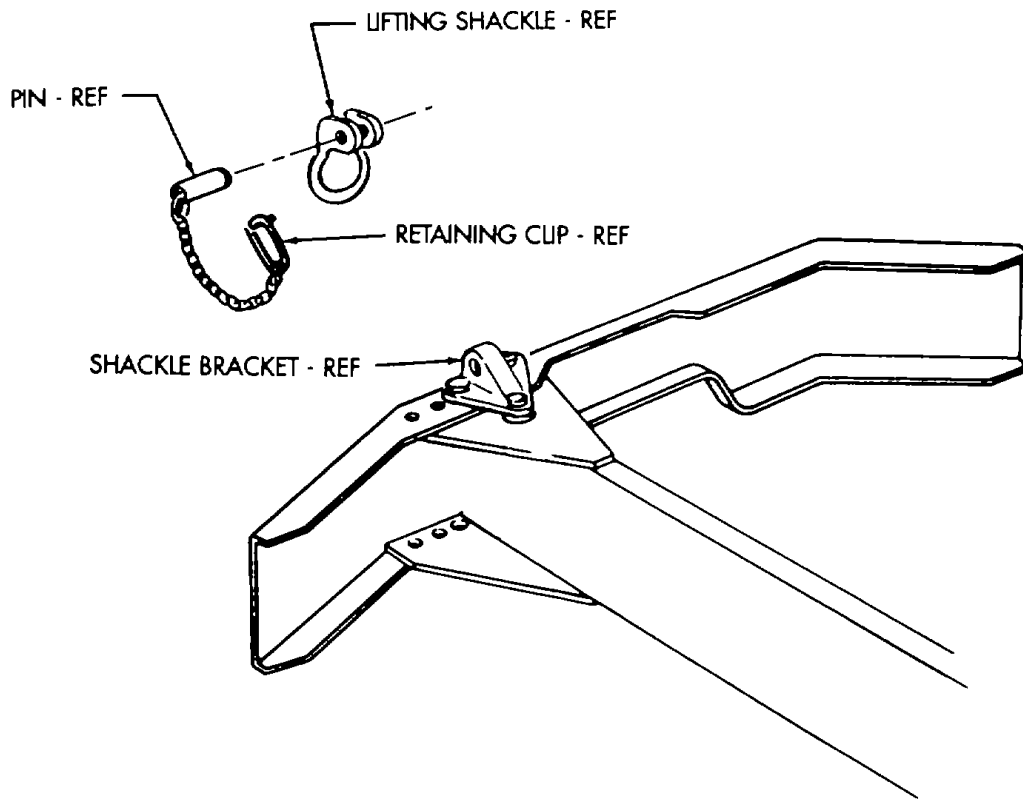

FIGURE 1

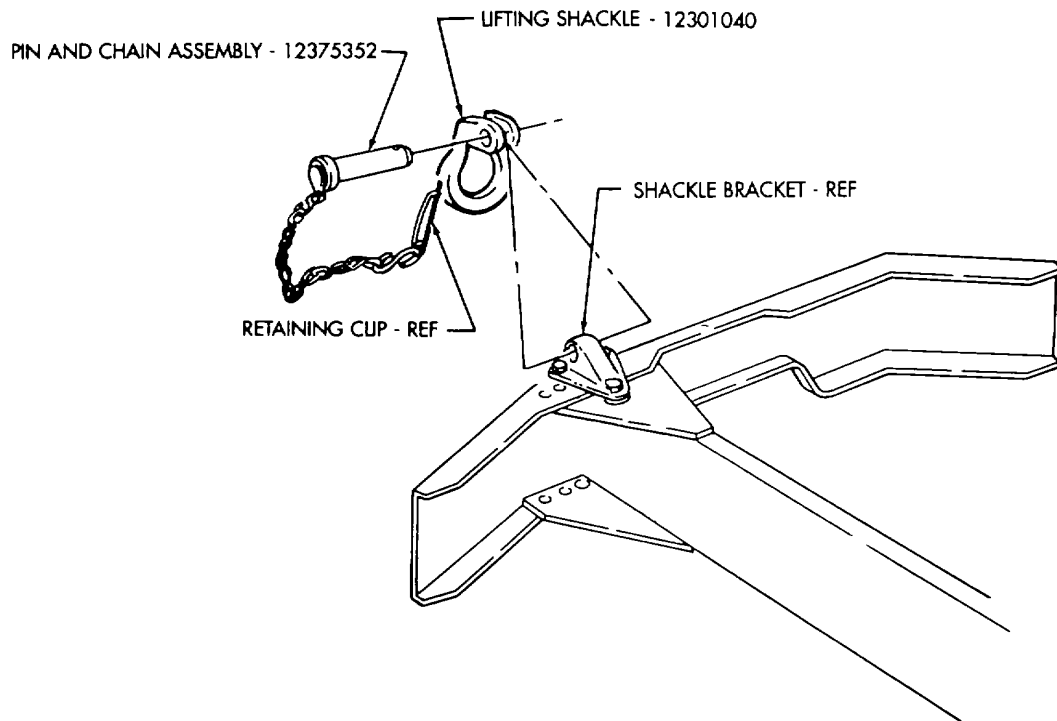

FIGURE 2

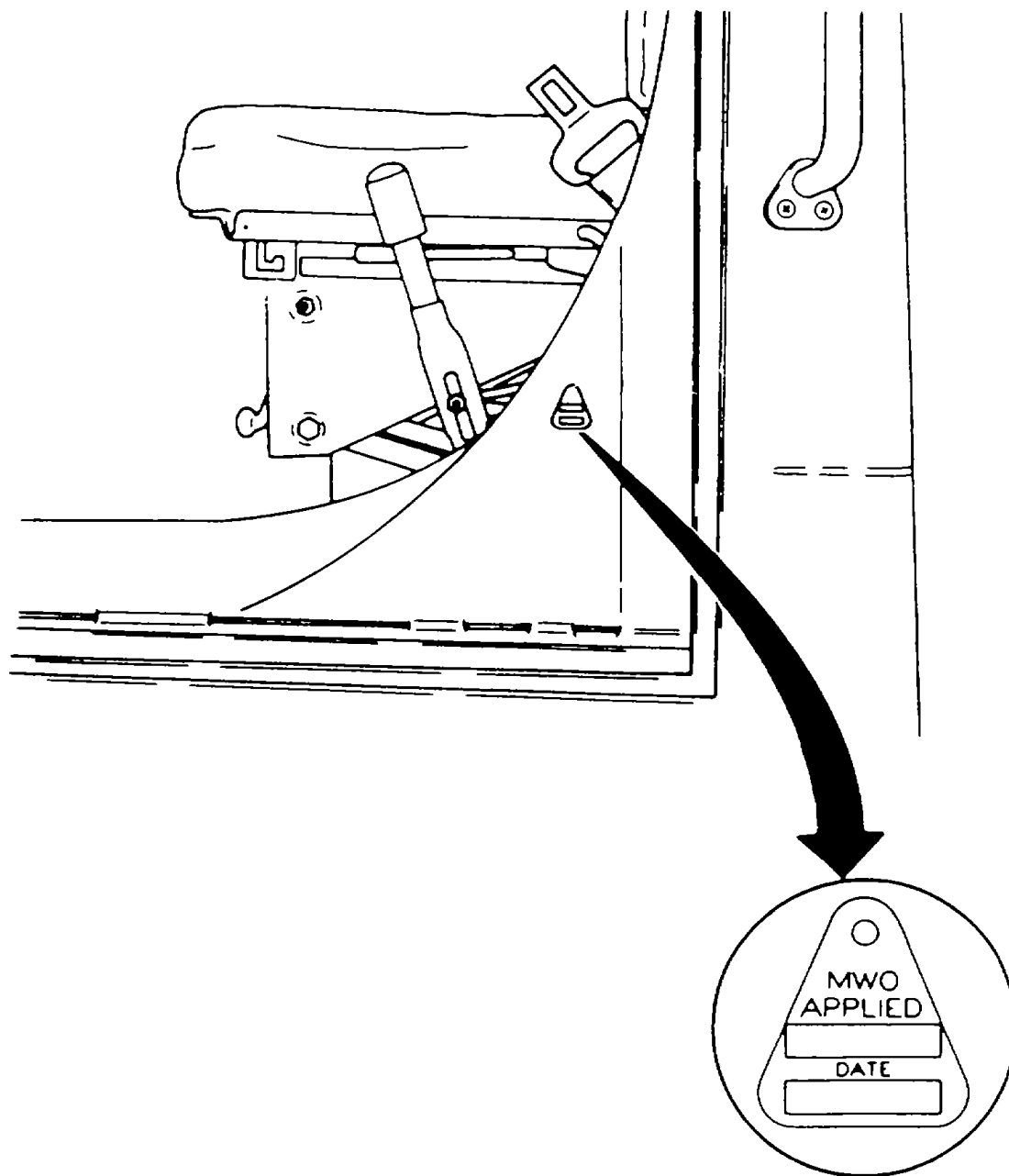
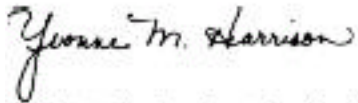

FIGURE 3

By Order of the Secretary of the Army



*Administrative Assistant to the
Secretary of the Army
01388*

DENNIS J REIMER
*General, United States Army
Chief of Staff*

DISTRIBUTION

To be distributed in accordance with DA Form 12-38-E, block 1014, requirements for MWO 9-2320-272-20-5

BLANK PAGE

OR

STRIP-IN PAGE

RECOMMENDED CHANGES TO EQUIPMENT TECHNICAL PUBLICATIONS



SOMETHING WRONG WITH THIS PUBLICATION?

THEN... JOT DOWN THE DOPE ABOUT IT ON THIS FORM, CAREFULLY TEAR IT OUT, FOLD IT AND DROP IT IN THE MAIL!

FROM: (PRINT YOUR UNIT'S COMPLETE ADDRESS)

DATE SENT

PUBLICATION NUMBER

PUBLICATION DATE

PUBLICATION TITLE

BE EXACT... PIN-POINT WHERE IT IS				IN THIS SPACE TELL WHAT IS WRONG AND WHAT SHOULD BE DONE ABOUT IT:
PAGE NO.	PARA-GRAPH	FIGURE NO.	TABLE NO.	

PRINTED NAME, GRADE OR TITLE, AND TELEPHONE NUMBER

SIGN HERE:

TEAR ALONG PERFORATED LINE

DA FORM 2028-2
1 JUL 79

PREVIOUS EDITIONS ARE OBSOLETE.

P.S.—IF YOUR OUTFIT WANTS TO KNOW ABOUT YOUR RECOMMENDATION MAKE A CARBON COPY OF THIS AND GIVE IT TO YOUR HEADQUARTERS.

